

Hyworth 2.0T 3 Wheel Electric Counterbalance

| | | | | | |
|----------------------------|-------------------------|---|---|--------------------|------------|
| Distinguishing Mark | 1.1 | Hyworth 2.0T 3 Wheel Electric Counterbalance | | | |
| | 1.2 | Model Number | | H20BE3W | |
| | 1.4 | Operator Type | | Seated | |
| | 1.5 | Rated Capacity / rated load | Q (kg) | 2000 | |
| | 1.6 | Load centre distance | c (mm) | 600 | |
| | 1.8 | Load centre distance | c (mm) | 360 | |
| | 1.9 | Wheelbase | y (mm) | 1466 | |
| Weight | 2.1 | Service Weight | kg | 3470 | |
| | 2.2 | Axle loading: laden front / rear | kg | 4350 / 720 | |
| | 2.3 | Axle loading: unladen front / rear | kg | 1530 / 1940 | |
| Tyres, chassis | 3.1 | Tyres | | solid | |
| | 3.2 | Tyre Size: front | mm | 200 / 50-10 | |
| | 3.3 | Tyre size: rear | mm | 15 x 4.5 - 8 | |
| | 3.5 | Wheel: number front / rear (x + driven wheels) | | 2 x /2 | |
| | 3.6 | Tread: front | b10 (mm) | 915 | |
| | 3.7 | Tread: rear | b11 (mm) | 175 | |
| | Dimensions | 4.1 | Tilt pf mast / fork carriage forward / backward | α/β (°) | 5.5/6 |
| 4.2 | | Height: mast lowered | h1 (mm) | 1995 | |
| 4.3 | | Free lift | h2 (mm) | 145 | |
| 4.4 | | Lift | h3 (mm) | 3000 | |
| 4.5 | | Height: mast extended | h4 (mm) | 3945 | |
| 4.7 | | Height of overhead guard STD | h6 (mm) | 2040 | |
| 4.9 | | Seat height / stand height | h7 (mm) | 1000 | |
| 4.12 | | Coupling height | h10 (mm) | 500 | |
| 4.19 | | Overall length | l1 (mm) | 2930 | |
| 4.20 | | Length to face of forks | l2 (mm) | 2010 | |
| 4.21 | | Overall width | b1 (mm) | 1120 | |
| 4.22 | | Fork dimensions ISO 2331 | s/e/l (mm) | 40/122/920 | |
| 4.23 | | Fork carriage DIN 15 173 – ISO 2328: class type A,B | | ISO2328 2A | |
| 4.24 | | Fork carriage width | b3 (mm) | 1000 | |
| 4.25 | | Distance between fork arms | b2 (mm) | 240/1000 | |
| 4.31 | | Ground clearance, laden, below mast | m1 (mm) | 100 | |
| 4.32 | | Ground clearance, centre of wheelbase | m2 (mm) | 110 | |
| 4.34.1 | | Aisle width for pallets 1000 x 1200 crossways | Ast (mm) | 3342 | |
| 4.34.2 | | Aisle width for pallets 800 x 1200 lengthways | Ast (mm) | 3465 | |
| 4.35 | | Turning radius | Wa (mm) | 1660 | |
| 4.36 | Internal turning radius | b13 (mm) | 15/15 | | |
| Performance Data | 5.1 | Travel speed: laden / unladen | km/h | 0.350/0.450 | |
| | 5.2 | Lift speed: laden / unladen | m/s | 0.470/0.420 | |
| | 5.3 | Lowering speed: laden / unladen | m/s | 3050/3700 | |
| | 5.5 | Drawbar pull: laden / unladen | N | 11200 / 11000 | |
| | 5.6 | Max. Drawbar pull: laden / unladen | N | 13/15 | |
| | 5.7 | Gradeability: laden / unladen | % | 15/18 | |
| | 5.8 | Max. Gradeability: laden / unladen | % | 4.9/4.5 | |
| | 5.10 | Service brake | | Hydraulic | |
| | 5.11 | Parking brake | | Mechanical | |
| | Electric engine | 6.1 | Drive motor rating S2 60 min | kW | 4.8 x 2 AC |
| | | 6.2 | Lift motor rating at S3 15% | kW | 9.5 AC |
| 6.3 | | Battery acc. To DIN 43 531/35/36 A,B,C no | | DIN43531 A | |
| 6.4 | | Battery voltage: rated capacity | V/Ah | 48/600 | |
| 6.5 | | Battery weight | kg | 1000 | |
| | | Battery dimensions | l/b/h (mm) | 830x738x627 | |

| | | | | |
|------------------------|------|---|--------|-----------|
| | 6.6 | Energy Consumptions acc. to VDI cycle | kWh/h | 4.4 |
| | | Minimum battery weight | kg | 900 |
| | | Maximum battery weight | kg | 1100 |
| | 8.1 | Type of drive control | | MOSFET/AC |
| | 9.1 | Manufacturer | | ZAPI |
| Additional data | 10.1 | Operating pressure for attachments | bar | 150 |
| | 10.2 | Oil volume for attachments | l/min | 35 |
| | 10.3 | Hydraulic Tank = capacity (drain & fill) | litre | 29 |
| | 10.7 | Sound level at the drivers ear according to EN/DIN 12 053 | dβ (A) | 74 |
| | 10.8 | Towing coupling, type DIN | | ø24 Pin |

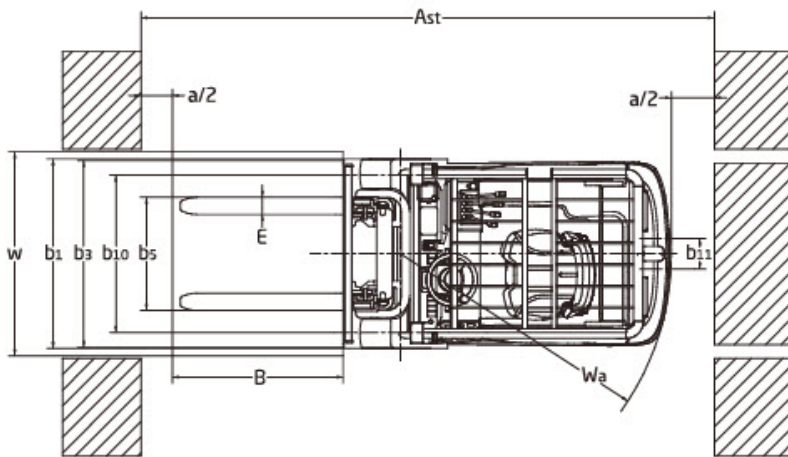
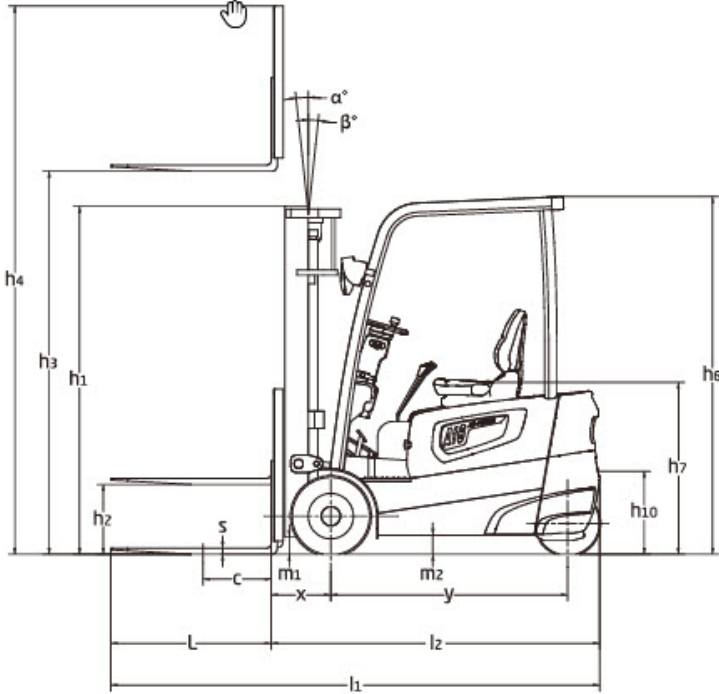

a=200mm safety clearance
 $Ast = a + Wa + \sqrt{(X+B)^2 + (W/2)^2}$

X: Load distance
 B: Length of load or forks which is longer

HYWORTH®

FORKLIFTS

2/12 Weld Street PRESTONS NSW 2170
 1300 HYWORTH (1300 499 678)
 info@hyworthforklifts.com.au
 www.hyworthforklifts.com.au