

Hyworth 2.2T Lithium Electric Pallet Mover

Distinguishing Mark	1.1	Hyworth 2.2T Lithium Electric Pallet Mover			
	1.2	Model Number		H22PM-Li	
	1.4	Operator Type		Pedestrian	
	1.5	Rated Capacity / rated load	Q (kg)	2200	
	1.6	Load centre distance	c (mm)	600	
	1.8	Load centre distance, centre of drive axle to fork	c (mm)	1000	
	1.9	Wheelbase	y (mm)	1444	
Weight	2.1	Service Weight (without battery)	kg	360	
Tyres, chassis	3.1	Tyres		PU	
	3.2	Tyre Size: front	mm	Φ230×75	
	3.3	Tyre size: rear	mm	Φ82.5×114	
	3.5	Wheel: number front / rear (x + driven wheels)		1x+/2	
	3.6	Tread: front	b10 (mm)	910	
	3.7	Tread: rear	b11 (mm)	510	
	Dimensions	4.1	Lift	h3 (mm)	140
4.2		Fork Height: lowered	h13 (mm)	85	
4.3		Overall length	l1 (mm)	1790	
4.4		Length to face of forks	l2 (mm)	640	
4.5		Overall width	b1 (mm)	710	
4.6		Fork dimensions ISO 2331	s/e/l (mm)	60/170/1150	
4.7		Distance between fork arms	b5 (mm)	680	
4.8		Ground clearance, centre of wheelbase	m2 (mm)	23	
4.9		Turning radius	Wa (mm)	1550	
Performance Data	5.1	Travel speed: laden / unladen	km/h	6/6	
	5.2	Lift speed: laden / unladen	m/s	0.045/0.06	
	5.3	Lowering speed: laden / unladen	m/s	0.05/0.04	
	5.4	Drawbar pull: laden / unladen	N	12000/12000	
	5.5	Max Gradeability: laden / unladen	%	10/16	
Electric engine	6.1	Drive motor rating S2 60 min	kW	1.3	
	6.2	Lift motor rating at S3 10%	kW	1.2	
	6.3	Battery voltage: rated capacity	V/Ah	24/125	

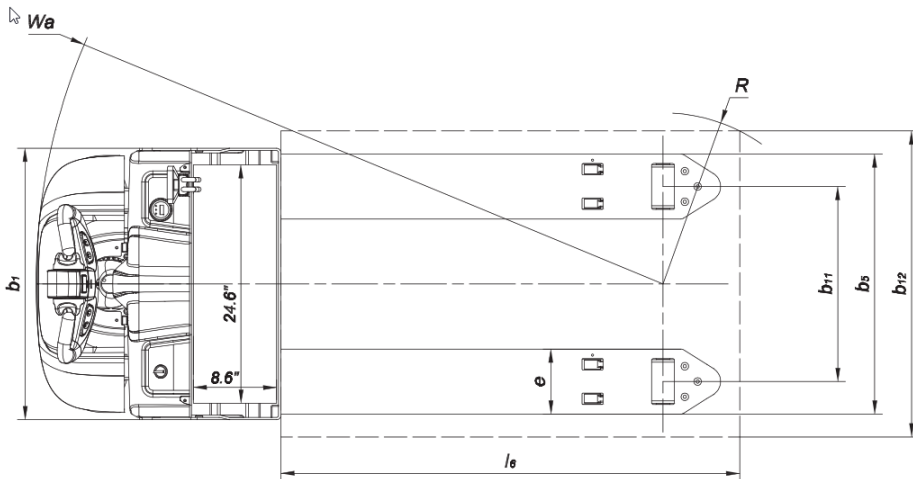
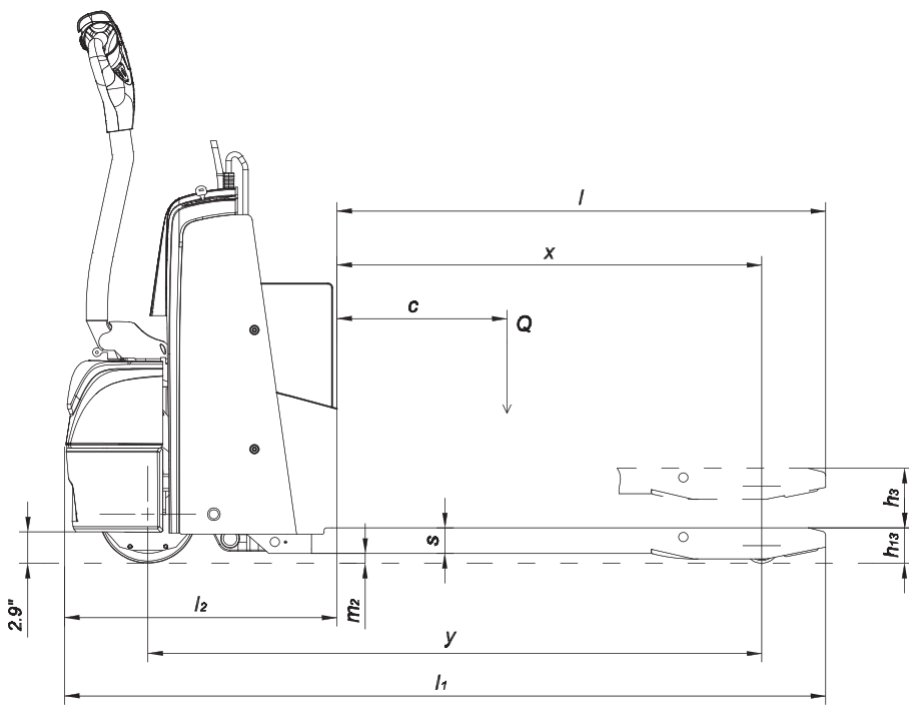

HYWORTH®

FORKLIFTS

2/12 Weld Street PRESTONS NSW 2170
 1300 HYWORTH (1300 499 678)
info@hyworthforklifts.com.au
www.hyworthforklifts.com.au